

FC-201/B Data Transceiver

USER MANUAL



SHENZHEN FRIENDCOM TECHNOLOGY DEVELOPMENT CO. , LTD

**Address: 2/F, Multifunction Building, Dongpeng Industrial Park, Wuhao Road, North Section of
Hi-tech Park, Shenzhen 518057 China**

Tel: +86-755-86026603 +86-755-29926100

Fax: +86-755-86026300

E-mail: faq@friendcom.com

Website: <http://www.friendcom.cn>

TABLE OF CONTENTS

TABLE OF CONTENTS-----1

GENERAL OVERVIEW-----2

FEATURES OF FC-201/B-----2

TECHNICAL SEPCIFICATION-----2

MAIN PARTS OF FC-201B-----3

SHAPE AND INTERFACE-----3

CONNECTED WITH THE TERMINAL AND PARAMETER SETTING-----5

DATA TRANSMISSION PROTOCOL-----6

WIRELESS NETWORK AND PROGRAMMING-----11

TYPE DESCRIPTION-----13

THE DEFAULT SETTING AND ACCESSORIES-----13

I. General overview

The product is a modularized half duplex data transmission radio with large power output. It adopts multiple advanced techniques such as SCM, RF and digital processing etc. SMT and high quality components are used in production. Its technical specifications satisfy GB/T16611-1996.

FC-201/B can operate in E protocol and transparent P protocol. It is suitable for various communication environment to implement point to point or point to multi-point networking. The addressing capacity is 4096. FC-201/B is widely used in GPS , remote sensing, remote test , remote communication, monitoring the mobile object and industrial automation, especially there will be a wide application in gas, chemical industry , irrigation works, electric power industry, weather, traffic, railway, mine, public security, defence, house intelligentization, and etc.

II. Features of FC-201/B

1. Dual PLL and dual VCO.
2. Advanced modulation mode MSK for reliable data transmission.
3. The working frequency covers 20MHz.
4. Store 16 receiving /transmitting channels.
5. Operating in multiple communication protocols with high compatibility.
6. Providing RS-232/RS-485/UART(TTL level) interface, easy to connect with various equipments.
7. Built-in software watchdog to ensure long-time reliable work.
8. SMT assembly, high integration and advanced technics.
9. Modularized design for convenient embedding.

III. Technical specifications of FC-201/B

1. General specifications:

- 1) Frequency range: VHF/UHF
- 2) Channel spacing: 25kHz/12.5kHz optional
- 3) Frequency stability: ± 5 ppm
- 4) Modulation mode: MSK
- 5) Air data rate: 2,400/1,200bps
- 6) Channel: 16
- 7) Antenna impedance: 50 Ω
- 8) Temperature: -20 ~ 60 $^{\circ}$ C
- 9) Size: 106 x 54 x 18mm
- 10) Weight: 150g

2. Specifications of receiver:

- 1) Sensibility: $\leq 0.25 \mu$ V(12dB SINAD)
- 2) Adjacent channel selectivity: ≥ 65 dB
- 3) Frequency deviation: $\leq \pm 5.0$ kHz
- 4) Spurious rejection ≥ 65 dB
- 5) Intermodulation: ≥ 65 dB
- 6) Audio distortion: $\leq 3\%$

3. Specifications of transmitter:

- 1) RF power: 5W /2W
- 2) Adjacent channel rejection: ≥ 65 dB
- 3) Audio distortion: $\leq 3\%$
- 4) Transmitter startup time: ≤ 50 ms

4. Interface: RS-232, RS-485, UART/TTL data rate: 1,200 ~ 9,600bps optional, format: 8N1/8E1/8O1.

5. Power supply: DC 9~15V, 13.8V typical

6. Consumption current:

Standby current(reception status) : $\leq 60\text{mA}$

Transmitting current: $\leq 2.0\text{A}(13.8\text{V}, \text{RF power } 5\text{W})$

$\leq 1.0\text{A}(13.8\text{V}, \text{RF power } 2\text{W})$

IV. Main Parts of FC-201/B

FC-201/B is mainly composed of transmitter, receiver, PLL, baseband processing and MODEM, CPU, interface (RS-232/RS-485/UART(TTL level)) (shown as fig.1).

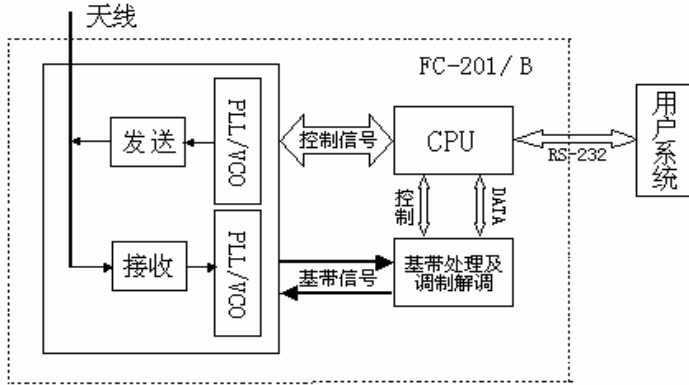

Fig.1

- (1) Transmitter: Modulate the baseband signal to radio frequency and amplify its power.
- (2) Receiver: Demodulate the RF signal and amplify it to baseband signal.
- (3) PLL: Providing standard high-stability RF signal for transmitter and receiver
- (4) Baseband processing and MODEM: This part carry out processes such as filtering, amplifying and reshaping, modulating/demodulating, encrypting/ decrypting and squelching.
- (5)CPU: To carry out interface control, parameter setting and data processing etc.
- (6)Interface RS-232/RS-485: data exchange with the user's terminal.

V. Shape and Interface

1. Shape

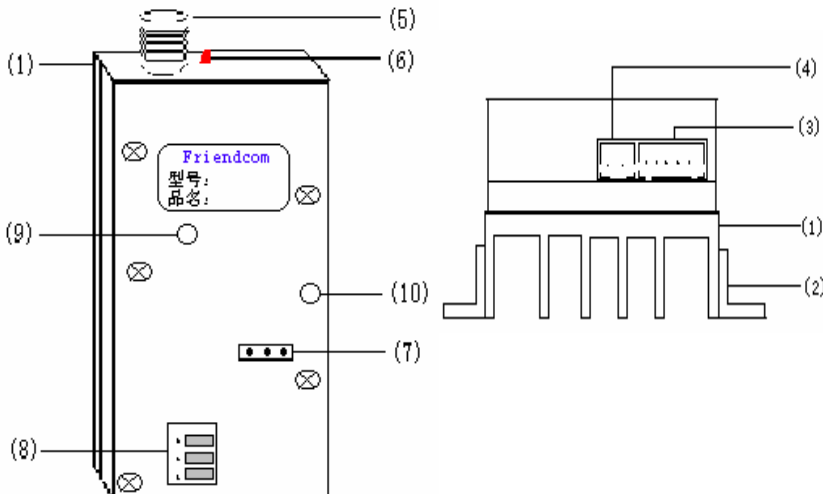

Fig.2

- (1) Heat sink: It is used to radiate heat for the RF module to ensure long-time reliable work.. Its size is 105 x 54 x 17mm
- (2) Fixing hole: For fixing FC-201/B
- (3) User's interface: 5-pin port used to connect with terminal.
- (4) Power supply: 2-pin port , +13.8V indicates positive pole, GND indicates cathode(negative).
- (5) Antenna port: N-TNC connector, the core is female, with external screw thread ,the impedance is 50Ω.
- (6) Transmitting /receiving indicator light: Red light is on while transmitting, green light is on while receiving.
- (7) Testing port: Used for RSSI, AT (Audio Tone) and SQ.
- (8) Interface RS-232/RS-485/UART(TTL) selection : To choose RS-232 or UART(TTL) with jumper wire as the following figure.



Note: We design another FC-201/B with interface RS-485, and the other parts are the same.

- (9) Power tuner: It has been adjusted well while Ex-works.
- (10) SQ tuner: It has been adjusted well while Ex-works.

2. The definition of User Interface

5-pin port of FC-201/B is shown in fig. 3. The definition of each pin is listed below.

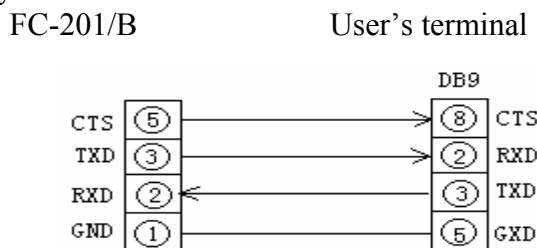

Fig.3

- ① GND
- ② RxD—Receiving Data End: Input of FC-201/B used to receive the data from the terminal.
- ③ TxD—Transmitting Data End: Output of FC-201/B used to transmit data to the terminal.
- ④ Reset: Reset signal, TTL level, if input a TTL low level of 150ms, FC-201/B will reset.
- ⑤ CTS—Clear-to-Send: Output. If the buffer of FC-201/B is full or disable to receive data for other reasons, The module sets CTS to forbid transmission (TTL to be '1', convert to -12V of RS-232), and the upper device stops transmitting data after receiving CTS until CTS is allowed transmission again (TTL to be '0', convert to +12V of RS-232).

3. Connecting to terminal via RS-232.

Usually the module is connected to terminal via RS-232(shown as below).



4. Connecting to SCM.

The module is connected to SCM via UART (TTL) (shown as below).

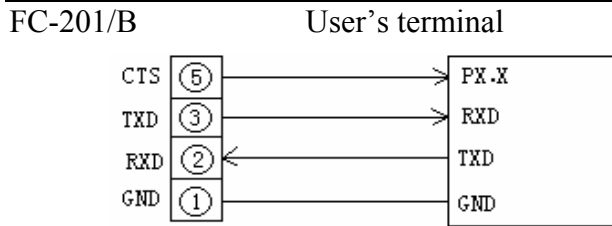

5. Connecting to terminal via RS-485.

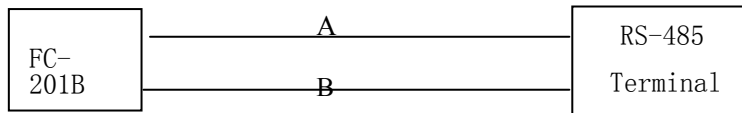

VI.Connected with the terminal and parameter setting.

The necessary setting and online debugging is needed before using the module. The steps are listed below.

1. Connection before power-on.

- a. Connecting the antenna port with antenna or dummy load, the working frequency of the connected antenna is same with the actual frequency of the module.
- b. Connecting FC-201/B to +13.8V DC power supply (**Notes:** the red wire is connected to the positive pole of power supply)
- c. Connecting more than two modules with computers respectively via the attached RS-232 cable. The connection sketch is shown below.
- d. Install the DEMO testing software to the computer.

2. Power-on examination

- a. Turn on the +13.8V DC power supply
- b. Carry out communication and data transmission in default setting for examination.

3. Data transmission examination.

- a. Connect the two being tested FC-201/B to computers, turn on the power and set the channel to channel 8.
- b. Run the setting software, reading the parameters of the module, which will be the same with its default setting.
- c. Select the menu 'data transmission', input the prepared word or numbers and press the 'send' button. Two modules will transmit data continuously, and the screen of the computer displays the transmitted data. It indicates data transmission works well.

4. Setting parameters

The setting for parameters should be carried out if the needed parameters of user's network are different from the default ones. User can change the default setting stored in the module such as carrier frequency, air data rate, interface data rate and protocol to meet the needs of the practical network. The steps for setting parameters are listed as the following.

- a. Run the software and open the menu for setting.
- b. Select the item to be changed. For example, if we want to change the frequency, first inputting the needed frequency, then pressing the setting button and the new frequency is set well. One thing should be noticed that the transmitting frequency of the master is the same as the receiving one of the slave

when the receiving frequency of the master is the same as the transmitting one of the slave. But the receiving/transmitting frequency of the same module can be diverse.

c. System code and address code should be encoded in network.

VII. Data transmission protocol

There are two types of data transmission protocol known as P-protocol and E-protocol in FC-201/B. P-protocol has three modes: Addressing mode, General mode and transparent mode, which can be set with DEMO software. E-protocol is a all-transparent protocol.

1. The meaning of three mode of P-protocol and data process.

1.1. The meanings of addressing mode

In addressing mode, FC-201/B uses address code to decide whether a frame of data is valid and whether to keep or discard the frame. The data is transmitted in a frame in this mode. Every data frame has an address code, the module decides whether to send the received data to the terminal according to address code. The mode has some protocols and regulations to reduce the complexity of application development, to shorten the development cycle. This mode is quite suitable in point to multi-point communication mode or the circumstance of limited development ability or time.

1.2. The frame format of addressing mode.

a. Setting Command of addressing mode (All the command word expressed in hex).

55	AA	Len(03)	30	00	Check sum(00 33)
----	----	---------	----	----	------------------

55 AA: Command frame header.

Len: The length of frame = Command word length +1

3000: Indicates addressing mode.

Check sum (2 bytes): The sum (16 bit)of all bytes behind 55AA, the overflow bits are ignored.

b. Channel switch command

55	AA	Len(06)	07	XX	00	00	00	Check sum(2 byte)
----	----	---------	----	----	----	----	----	--------------------

XX: The destination channel number (01H-10H)

c. Command to set the address of data transceiver

55	AA	Len(04)	32	Address code(2 byte)	Check sum(2 byte)
----	----	---------	----	----------------------	--------------------

The format of address code(2 byte) is shown below:

b15	b14	b13	b12	b11- b8	b7-bit0
0	0	0	0	System code (4bit)	The transceiver's address code (8bit)

System code: 00H-0FH (0-15)

The transceiver's address code: 00H-FFH (0-255)

d. The frame format for sending data

7E	Destination address code (2 byte)	Len (1 byte)	Data ≤ 72 byte
----	-----------------------------------	--------------	----------------

7E: The header of data frame (1 byte)

Len: The length of the frame= the length of data +1

The format of destination address code (2 byte) is shown below:

b15	b14	B1 3	b12	b11- b8	b7- bit0
Communication mode		0	0	System code (4bit)	FC-201/B transceiver's address code (8bit)

Where bit14-15 determine the communication mode of the data frame, its meaning shown in the following table :

bit15	bit14	Communication mode	description
1	X	Broadcast in all net	System code & address code are invalid, can be set to any value.
0	1	Broadcast in system	Should have a corresponding system code, address code can be set to any value.
0	0	Point to point communication	Should have a corresponding system code and address code.

e. The frame format for receiving data

7E	Len (1 byte)	Source address code (2 byte)	Data ≤ 72 bytes
----	--------------	------------------------------	-----------------

7E: The header of data frame (1 byte)

Len: The length of the frame= the length of data +1

The format of destination address code (2 byte) is shown below:

b15	b14	B1 3	b12	b11- b8	b7- bit0
Communication mode		0	0	System code (4bit)	The transceiver's address code (8bit)

Where bit14-15 determine the communication mode of the data frame, its meaning shown in the following table :

bit15	bit14	Communication mode description
1	X	Receiving broadcast in the net.
0	1	Receiving broadcast in the system
0	0	Just receiving the data sent to the local transceiver.

f. The response frame in 1 second after the transceiver receives a setting command from the user's terminal.

Command code	Description
55 AA 02 20 00 22	The setting is correct.
55 AA 02 21 00 23	The setting fails.
No response in 1s	Response is wrong or no response

g. The response frame in 1 second after the transceiver receives a data frame from user's terminal.

Command code	Description
55 AA 00	The data frame from RS-232 is correct and has been sent out, the next data frame can be sent.
55 AA EE	The data frame from RS-232 is wrong.
55 AA FF	The data frame from RS-232 is correct, but at present the data cannot be sent out.

h. The frame structure of feedback to user’s terminal while the transceiver receiving wrong data from air .

Command code	Description
55 AA DD	The received data frame from air is wrong

1.3. The meanings of general mode

General mode is designed for user’s self-definition upper communication process. The data is transmitted as a frame without any process. The transceiver sends a data frame from terminal to the air directly while transmitting; and the transceiver sends a data frame from air to user’s terminal directly while receiving. The valid data buffer is 72 byte, so the valid data for each frame is less than 72 byte.

1.4. The frame format of general mode.

a. Setting Command of general mode (All the command word expressed in hex).

55	AA	Len(03)	31	00	Check sum(00 34)
----	----	---------	----	----	------------------

55 AA: Command frame header.

Len: The length of frame = Command word length +1

3100: Indicates addressing mode.

Check sum (2 bytes): The sum (16 bit)of all bytes behind 55AA, the overflow bits are ignored.

b. Channel switch command

55	AA	Len(06)	07	XX	00	00	00	Check sum(2 byte)
----	----	---------	----	----	----	----	----	--------------------

XX: The destination channel number (01H-10H)

c. The frame format for sending data

7E	Len (1 byte)	Data ≤ 72 bytes
----	--------------	-----------------

7E: The header of data frame (1 byte)

Len: The length of the frame= the length of data +1

d. The frame format for receiving data

7E	Len (1 byte)	Data ≤ 72 bytes
----	--------------	-----------------

7E: The header of data frame (1 byte)

Len: The length of the frame= the length of data +1

e. The response frame in 1 second after the transceiver receives a setting command from user’s terminal.

Command code	Description
55 AA 02 20 00 22	The setting is correct.
55 AA 02 21 00 23	The setting fails.

No response in 1s	Response is wrong or no response
-------------------	----------------------------------

f. The response frame in 1 second after the transceiver receives a data frame from user’s terminal.

Command code	Description
55 AA 00	The data frame from RS-232 is correct and has been sent out, the next data frame can be sent.
55 AA EE	The data frame from RS-232 is wrong.
55 AA FF	The data frame from RS-232 is correct, but at present the data cannot be sent out.

g. The frame structure of feedback to user’s terminal while the transceiver receiving wrong data from air.

Command code	Description
55 AA DD	The received data frame from air is wrong

1.5. The meanings of transparent mode

Transparent mode is designed for user to completely self-definite upper communication process. The data from user’s terminal is sent to air without any process. The data from air is transmitted to user’s terminal without any process. The transceiver just acts as a bridge in data transmission.

In Transparent mode, Data flow control of RS-232 is carried out through CTS between the transceiver and the terminal. If CTS signal is valid (low level), It indicates that the data buffer is full, user’s terminal should stop sending data to the transceiver. If CTS signal is invalid (high level), It indicates that the data buffer is not full, user’s terminal is able to send data to the transceiver. FC-201/B’s capacity of data buffer is 72 byte. Generally, User’s terminal should stop sending data based on valid or invalid CTS after continuously sending 72 byte data to the transceiver.

1.6. The data format of transparent mode.

There is no command frame or data frame in transparent mode. Data flow is controlled through hardware CTS signal. When the transceiver acts as the air data sending end, if data cannot be transmitted because the buffer is full or other reasons, the CTS should be valid(set to low), otherwise The CTS is set to invalid (set to high). The

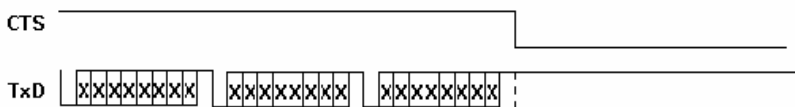

Fig. 6

timing is shown in fig.6:

If RS-232 of user’s terminal cannot receive CTS signal or control data flow by programming to CTS, A delay method can be used to control the data flow. Fig 7 shows the time interval between two data frames and its calculation method.

Where B is beginning time, typical value is 80ms.

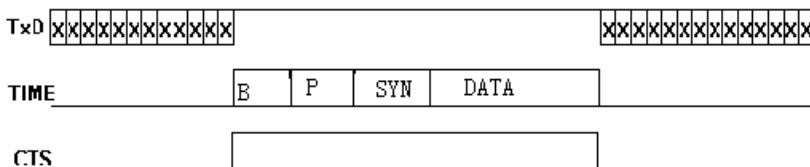

Fig. 7

P: indicates the time of sending 64 bit of pilot. The calculation method is:

$$\text{Time of pilot} = 64 * 1000 / \text{air data rate} \text{ ms}$$

SYN: indicates the time of sending 16 bit of synchronization. The calculation method is:

$$\text{Time of synchronization} = 16 * 1000 / \text{air data rate} \text{ ms}$$

DATA: indicates the time of sending valid data, the calculation method is:

$$\text{Time of data} = (\text{bytes of data} + 3) * 8 * 125\% * 1000 / \text{air data rate} \text{ ms}$$

The total time is the sum of the above four items.

For example, the bytes of sending data is 72, air data rate is 1200bps, the time interval is :

$$\begin{aligned} \text{Time interval} &= 80 + 64000 / 1200 + 16000 / 1200 + (72 + 3) * 8 * 125\% * 1000 / 1200 \\ &\approx 80 + 53.3 + 13.3 + 625 \\ &\approx 772 \text{ms} \end{aligned}$$

1.7. The process of sending and receiving data for P-protocol.

We take addressing mode as an example to describe as the following.

a. The user's terminal sends the below data to the transceiver:

7E	Destination address code	Len	Data
----	--------------------------	-----	------

b. After the transceiver receives the data:

- a) Check whether the frame structure is correct, if it's wrong, then send back 55 AA EE;
- b) Check whether data transmission is enabled at present, if not, then send back 55 AA FF.

c. if the transceiver is sure to have received the correct data structure, it will transform the data to radio transmission format and add error-correction encode.

The data frame format while transmitting in the air is shown below:

SYN code	Len	Destination address code	Source address code	data	CRC
----------	-----	--------------------------	---------------------	------	-----

Note: Bit 15,14 of source address code is replaced by the corresponding bits of destination address code.

- d. Send out the data.
- e. Send back 55 AA 00 to inform user's terminal to send the next frame data.

2. The meaning of E-protocol and data process flow.

2.1. The meaning of E-protocol

E-protocol is a all-transparent data transmission mode. That's to say FC-201/B can send the data to the receiver without any change regardless the upper protocol and the data structure. E-protocol is widely used in electricity meter reading, RTU with address, PLC and various SCM application area.

For E-protocol data transmission, there exist the following cases if its interface data rate is different from the air data rate.

- ① Data transparent transmission is available when its interface data rate is equal to or less than the air data rate.
- ② The max transmission data is 66 bytes one time if the interface data rate is more than air data rate.

2.2. E-protocol data transmission process.

After power-on, FC-201/B keeps in receiving status, if a signal is detected, FC-201/B will receive and process it, and store it in the memory of SCM for about 100ms, then send the data to user's terminal through RS-232. If data is ready to send out, FC-201/B will firstly receive data via RS-232 from user's terminal, and store in the memory of SCM for about 100ms, then send out via antenna after baseband-processing and modulation

Its flow chart show as the following fig.8

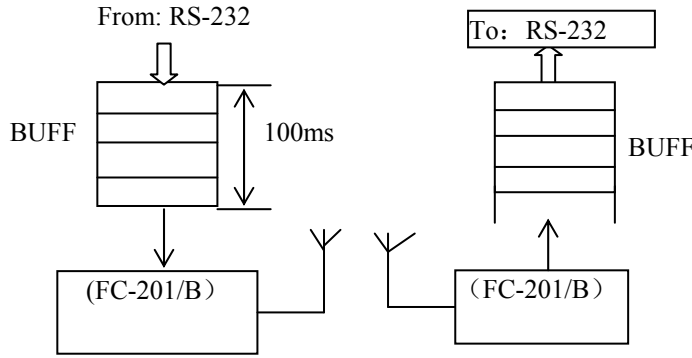

Fig.8

VIII. Wireless network and programming

It's a more complicated project to form a wireless network with FC-201/B especially for point to multi-point, multi-hierarchy management, dynamic channel assignment, which needs the support and control of system programming software. The notes for networking and programming are listed below.

1. To determine the communication protocol of network.

FC-201/B can support multiple communication modes such as point to multi-point, point to point etc. User can select one mode based on his needs.

Addressing mode is recommended to transmit data if point to Multi-point network is adopted, which will lightens the development burden of user's system or shortens the development cycle.

General mode is recommended to transmit data if point to point or other user-defined network is adopted. E-protocol is a preferable choice in wireless auto meter reading system.

2. To determine the working channel.

FC-201/B can work in single channel, multi-channel and dynamic channel assignment mode.

a) Single channel

Single channel is used in simple network or point to point communication. The channel No. and frequency of all the FC-201/B or its compatible modules in the network are the same.

b) Multi-channel

Multi-channel is applied in more complicated network with more users and large amount of data transmission. Channel frequency should be determined and then channel resources should be assigned in this mode. In general case, it is recommended that the maximal assigned channels are 4.

Assign each periphery radio based on its position or its user group. Every FC-201/B periphery module or its compatible modules in the same group work in a fixed channel, while the different user group uses different channel. As to central station a module should be configured for each channel. That's to say if 4

fixed channels is used, 4 modules of FC-201/B or its compatible ones should be installed in the central station.

Though more modules in central station are needed in multi-channel mode, the application development is relatively easy and the system is more reliable and efficient.

c. Dynamic channel assignment mode.

Dynamic channel assignment mode is applied in more complicated network with more users and large random data transmission quantity. It can work in two modes known as centralized resources management mode and random assignment mode. In the former mode the central station determines which channel the periphery radio will work in with a fixed control channel. The assigned channel will be canceled at the end of communication, and the next time channels will be assigned again.

In the latter mode, the periphery radios scan each channel periodically, and transmit the data in a spare channel. This mode is used if many periphery radios forwardly transmit data with central station

The application development is relatively complicated in dynamic channel assignment mode. But larger system capacity, more flexible network and high efficiency of frequency will be available.

3. Notes:

In system programming, Suitable communication protocol should be selected due to networking plan.

Programming should be carried out referring to the data structure of the P-protocol or E- protocol. It is worth to mention that some projects substitute the wire data transmission system with a wireless one, the below points should be taken into account because of the different transmitting way between wire and wireless system.

a) Data delay in wireless communication

Because the transmitter needs some startup time for stability, the transmission time of data will be long from master to slave and reverse. The master program should make the corresponding adjustment in timing.

b) Interface data flow control

FC-201/B is an intelligent data radio, its built-in MCU can provide some data buffer used for storing the received data or the data to be transmitted. Since the data buffer is limited, if the interface data rate is greater than the air one, the problem of data flow control should be considered. Or some data will be lost during interface communication.

4. Error control

The module just provides data transmission of link layer to user. If user needs to enhance the transmission reliability and flexibility of network, he can develop the protocol layer of the module such as adding slipping windows and error-corrected resending etc.

IX. Type description

The type description is shown below, please point out the needed type while making an order.

FC-201 / B 23 05 B

FC- indicates the product code name of manufacturer.

201 indicates series No.

B indicates Medium power

23 indicates the carrier frequency

23—220-240MHz, 41=400-420MHz, 46=450-470MHz

05 indicates RF power, 05=5W, 02=2W

P indicates communication protocol. E=E protocol, P=P protocol.

X.The default setting and accessories

a. The default setting of parameters and accessories.

The default setting		accessories:	
Channel No	8	DC 2-pin power supply cable	1
Serial port	Com1		
Interface data rate	1200bps	Manual book	1
Air data rate	1200bps	RS-232 port cable	1
Check	None	CD	1
Protocol	P (transparent)		

b. The default frequency of each channel for different freq range.

Range Channel	220 ~ 240MHz		400 ~ 420MHz		450 ~ 470MHz	
	Tx	Rx	Tx	Rx	Tx	Rx
Base frequency	220	220	400	400	450	450
Channel 1	223	223	403	403	453	453
Channel 2	224	224	404	404	454	454
Channel 3	225	225	405	405	455	455
Channel 4	226	226	406	406	456	456
Channel 5	227	227	407	407	457	457
Channel 6	228	228	408	408	458	458
Channel 7	229	229	409	409	459	459
Channel 8	230	230	410	410	460	460
Channel 9	231	231	411	411	461	461
Channel 10	232	232	412	412	462	462
Channel 11	233	233	413	413	463	463
Channel 12	234	234	414	414	464	464
Channel 13	235	235	415	415	465	465
Channel 14	236	236	416	416	466	466
Channel 15	237	237	417	417	467	467
Channel 16	238	238	418	418	468	468