

# FC-201/SA Micropower RF Module

## USER MANUAL



SHENZHEN FRIENDCOM TECHNOLOGY DEVELOPMENT CO. , LTD

Address: 2/F, Multifunction Building, Dongpeng Industrial Park, Wuhao Road, North  
Section of Hi-tech Park, Shenzhen 518057 China

Tel: +86-755-86026600 +86-755- 86026800 +86-755- 86026192

Fax: +86-755-86026300

E-mail: [faq@friendcom.com](mailto:faq@friendcom.com)

Website: <http://www.friendcom.cn>

## TABLE OF CONTENTS

TABLE OF CONTENTS-----	1
FEATURES OF FC-201/SA-----	2
APPLICATION OF FC-201/SA-----	2
HOW TO USE FC-201/SA-----	3
APPLICATION OF FC-201/SA NETWORKING-----	6
TECHNICAL SPECIFICATION OF FC-201/SA-----	6
DESCRIPTION OF TYPE-----	7
DEFINITION OF SERIAL NUMBER-----	7
COMMAND SET OF PARAMETER SETTING-----	7
DEFAULT SETTING AND ACCESSORIES-----	9

## I .Features of FC-201/SA

### 1. Micro power transmission

The maximum transmission power is 200 mW.

### 2. Built-in and modularized design

FC-201/SA can be embedded into the system of user as an independent communication unit.

### 3. High anti-interference and low BER(Bit error Rate).

Based on the MSK modulation mode, the high-efficiency FEC channel encoding technology is used to enhance data's resistance to both burst interference and random interference.

### 4. Super long transmission distance

In the open field, the reliable transmission distance is up to 800m when the antenna height is greater than 2m ([BER=10<sup>-3</sup>@1200bps](#)). And the reliable transmission distance is up to 1000m when the antenna height is greater than 3m (BER=10<sup>-3</sup>@1200bps).

### 5. Transparent data transmission

Transparent data interface is offered to suit any standard or nonstandard user protocol. Any false data generated in the air can be filtrated automatically (What has been received is exactly what has been transmitted).

### 6. Multi-channel

The standard FC-201/SA configuration provides 16 channels. If the user needs, it can be extended to 32 channels, meeting the multiple communication combination mode of the user.

### 7. Three interface modes

FC-201/SA can provide three transparent interfaces: RS232, RS485, UART/TTL The interface data rate is 1200~9600Bps optional and its format is 8N1/ 8E1/ 8o1 user-defined. It's convenient to directly connect with computer, user's RS-485 device, monolithic processor and other UART components for application.

### 8. Large data buffer

FC-201/SA can transmit more than 214 bytes long data frames at one time in any case. .if the RF data rate is greater than the interface rate, It can transmit infinitely long data frames.

### 9. Low power consumption

Receiving current is <40mA, transmitting current is <200mA, and sleep current is <5mA in mode one and <100uA in mode two respectively (UART/TTL interface)

### 10. Providing RSSI and SQ output

FC-201/SA can offer SQ (Output is high if signal in-band is detected, low if no signal detected) and RSSI (analog output with range of 60dB) to user for deep development or route testing.

### 11. High reliability, small and light

TCXO and all-metal housing structure used in FC-201/SA for high reliability and low failure rate.

### 12. Multiple antenna optional to meet user's various structure requirement

## II .Application of FC-201/SA

FC-201/SA is suitable for:

- ◆ Wireless meter reading
- ◆ Industrial remote control and telemetry
- ◆ Automatic data collecting system

- ◆ Building automation, safety and security, powerhouse equipment wireless monitor, entrance control system
- ◆ POS system, wireless keyboard, mouse
- ◆ Traffic, under-well locating ,alarm

### III. How to use FC-201/SA

#### 1. Power supply

FC-201/SA uses DC power supply with voltage of +3.6~5.0V. It can also share power supply with other equipment. However, the high quality power supply with desirable ripple factor should be selected. If possible, a manostat of 5V should be used for separate power supply. In addition, the reliable grounding must be ensured if there is other device in the system equipment. In case of failure to connect with the earth, it can form its own grounding. But it must be absolutely separated from the municipal electric supply. The power consumption will increase with the rising of work voltage. Generally standby current (in reception status) is about 25mA with a 5V voltage, and standby current (in reception status) is about 20mA with a 3.6V voltage. High data rate products with low consumption can be customized for the need of users.

#### 2. Definition of FC-201/SA connecting to terminal

FC-201/SA can provide one 10-pin connector (JP1), and its definitions as well as connection method with terminals are shown in table 1.

Table 1: Definition of connecting pins and connection method (from left to right)

Pin No.	Definition	Description	Level	Connected to terminal	remarks
1	GND	Signal grounding		Signal grounding	
2	RxD	Serial data Rx end	TTL/RS2	TxD	
3	TxD	Serial data Tx end	TTL/RS2	RxD	
4	CTS		TTL	RTS	
5	RSSI	Receiving signal strength indicator		Used for test	
6	SQ	Squelch indicator		Used for test	
7	485B	RS-485 B		B(TxD)	
8	485A	RS-485 A		A(RxD)	
9	VCC	Power supply DC			
10	GND	Power supply grounding			

### 3. FC-201/SA connected with terminal

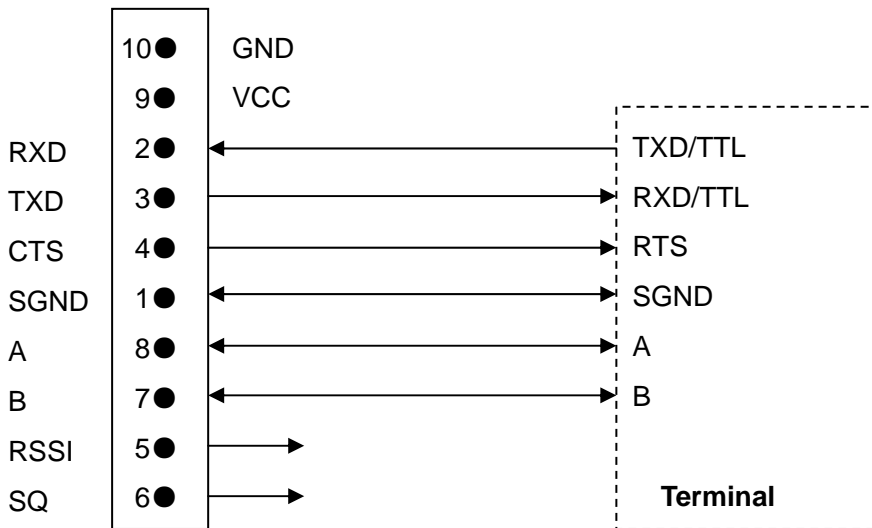

FC-201/SA

Fig 1. FC-201/SA connected with terminal schematics

### 4. Setting of channel, interface and data format

Before using FC-201/SA, user should determine the parameters of the following items based on its own needs.

#### A. Interface

FC-201/SA can provide three interfaces. User should determine one kind of interface while making an order.

#### B. Communication data rate

The communication data rate of FC-201/SA is 1200bps-9600bps optional, which can be set up with software by user.

#### C. Channel selection

FC-201/SA offers 4MHz frequency band, which can store 16 (can be extended to 32)channels of same or different frequency. User can change the frequency of each channel as well as just keep the default frequency.

#### D. Channel switching

Channel switching of FC-201/SA can be done with software.

#### E. Check mode

FC-201/SA interface supports check mode of 8E1, 8O1 or 8N1.10-bit data transmission needs to be customized if necessary.

**Note:** The communication data rate greater than 9600bps can not be set by user . It has been set in the factory according to user's requirement in his order.

### 5. Protocol and transmission capacity

The standard FC-201/SA provides transparent protocol to support various applications of user. Some special functions such as addressing, data collection and command explanation can be added on the base of transparent protocol to reduce cost or to lessen workload of terminal's CPU.

If interface data rate is less than RF data rate, infinitely long data can be transmitted at one time. (It is suggested to transmit data in packet).

If interface data rate is greater than RF data rate, 214 bytes of data can be transmitted at one time.

If interface data rate is equal to RF data rate, please refer to the following table.

Table 2.

Interface / RF data rate	Bytes transmitted at one time	
	Low consumption mode open	Low consumption mode close
1200/1200	Infinite length	Infinite length
2400/2400	>4K	>10K
4800/4800	>1K	>5K
9600/9600	214	About 1K

## 6. Description of low power consumption (sleep) function

FC-201/SA can work in sleep mode for less power consumption. The module alternates between work(standby reception status) and sleep status and it will delay 180ms for receiving after opening sleep function. The ratio of work/sleep time is 80ms/160ms.

There are two sleep modes known as sleep mode one and sleep mode two. The power supply is cut off in receiving circuit, but some hardware units of CPU keeps working in sleep mode one with consumption current of 5mA. If the interface has any data, the module will receive the data correctly and exit from sleep mode one and begin to transmit data in the air.

All the peripheral circuit is power down and CPU is out of work in sleep mode two with the least consumption of 100uA.If the interface has any data, the module will exit from this mode but will not receive the first byte of data correctly. A low pulse should be sent to wake up CPU on pin RXD, after an interval of 10ms the correct transmission is ensured.

### A. Usage of low power consumption function

The beginning and ending of low power consumption function can be set by command of software via interface. It's easy for user's MCU to manage consumption dynamically. It can be set with the delivered software of Friendcom.

### B. Notes:

It will delay 180ms for receiving in sleep mode. Furthermore, In sleep mode two, A low pulse should be sent to wake up CPU on pin RXD of FC-201/SA, after an interval of 10ms the correct transmission is ensured. Sleep mode two is not available in default cases, this function should be declared if user needs.

## 7. Structural size schematics

The following figure describes the structural size of standard FC-201/SA. Non-standard FC-201/SA of smaller size or distinct figure can be customized for various structural requirement of user.

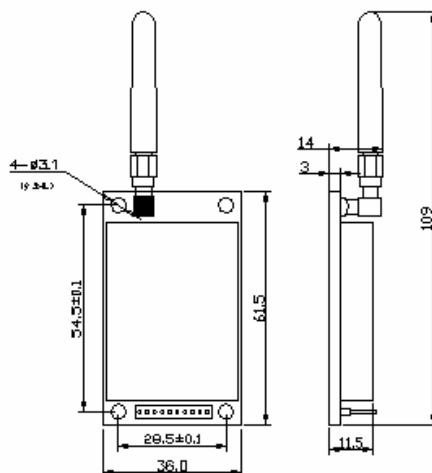

Fig.2. Structural size schematics

## 8. Antenna configuration

FC-201/SA can meet diverse antenna requirement of user. External helical antenna with SMA and SMT printed antenna are offered for user. In addition, various other antennas for micro power RF module are available too.

### a. SMA antenna

80mm helical antenna with SMA, high gain, low cost, transmitting long distance.

35mm magnetic antenna with SMA, high gain small, beautiful(like mobile antennas)。

### b. SMT printed antenna

SMT antenna is small with size of 30mm×7mm.It can be sealed on FC-201/SA PCB. The total length just adds 25mm for the antenna overlaps 5mm on PCB. The structure of FC-201/SA is more compact owing to the lessened size and thickness.

### c. Customization for special antenna

Various performance antenna can be designed and customized for special requirement.

## IV. Application of FC-201/SA networking

The communication channel of FC-201/SA is semi duplex, which is most suitable for the communication mode of point to multi-point. Under this mode, one master station must be set, and all of the rest are slave stations. A unique address is given to each station. The coordination of communication is controlled by master station that uses data frames containing address code to transmit data or command. Slave station will receive all of the data and command and compare the received address code with local address code. If they are different, the data will be deserted without any response. If those address codes are the same, it means the data is sent to the local. Slave station will make different responses according to the transmitted data or command and send back the response data. All these jobs must be performed by upper protocol, and it is assured that there is only one transmitter-receiver in the state of transmission in the communication network at any moment so as to avoid the cross-interference. FC-201/SA can also be used in point-to-point communication with easier operation. As to the programming of serial port, all you have to do is to remember that its communication mode is semi duplex while always observing the time sequence of come-and-go for receiving and transmitting.

## V. Technical specification of FC-201/SA

Modulation mode:	MSK
Carrier frequency:	487.00~491.00MHz, 430.00~440MHz. 144~148MHz
Frequency stability:	±2.5PPM
RF power:	200mW /300mW optional
Channel Spacing:	12.5kHz/25kHz
Receiving sensitivity:	-119dBm
Interface data rate:	1200~9600bps
Interface data format:	8E1/8N1/8O1
RF data rate:	1200~9600 bps
Temperature:	-20℃~70℃(Ordinary) -35℃~70℃(Industrial )
Power supply:	DC +3.6~+5.0V
Dimension:	61.5mm×36mm×12mm
Weight:	30g
Transmitting current:	≤200mA
Receiving current:	≤40mA

Humidity: 10%~90%RH, non-condensing

**Table 3: Corresponding frequency points of 1~16 channels**

Channel No.	Frequency	Channel No.	Frequency
1	487.250MHz	9	489.250 MHz
2	487.500MHz	10	489.500 MHz
3	487.750MHz	11	489.750MHz
4	488.000MHz	12	490.000MHz
5	488.250MHz	13	490.250MHz
6	488.500MHz	14	490.500MHz
7	488.750 MHz	15	490.750MHz
8	489.000 MHz	16	490.775MHz

Note: The corresponding frequency of each channel can be adjusted for user's need with setting software provided by Friendcom. The frequency must be multiple of 12.5kHz/25KHz (Channel spacing is 12.5kHz/25kHz), or the setting is incorrect.

## VI. Description of type

FC-201 indicates product series of Shenzhen Friendcom Telecom Co., Ltd., SA indicates micro power, i.e transmission power is 200mW, 96 indicates interface data rate 9600bps, 490 indicates carrier frequency 490M, the detailed definition is shown below:

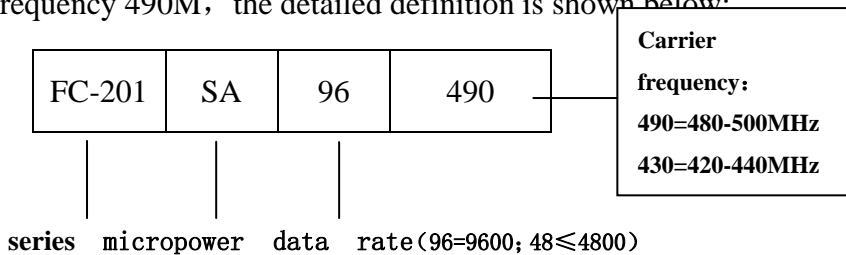

## VII. Definition of serial number

Every FC-201/SA has an exclusive serial number of 10 figures as its ID. As an example, Its definition is shown below :

04	09	01	0001
----	----	----	------

- 04: two figures, indicating year
- 09: two figures, indicating month
- 01: two figures, indicating day
- 0001: four figures, indicating sequence number.

## VIII. Command set of parameter setting.

User can read or set the parameters of FC-201/SA with the delivered software such as interface data rate, RF data rate ,channel number and address code etc. Also you can configure FC-201/SA based on the following command set by programming.

### Command frame format:

Table 4

Command frame header	Frame length	Command word	Check sum
----------------------	--------------	--------------	-----------

Command frame header: 55H AAH

Frame length = Command word length +1

Command word: less than 8 bytes

Check sum (2 bytes): Frame length +command data 1+...+command data n

All of the command word expressed in hex.

**Table 5.**

Command type	Frame header	Frame length	Command word	Check sum	remarks
Channel No.	55 AA	06	07 XX 00 00 00		XX=01-10(16 channels)
RF data rate setting	55 AA	04	20 05 XX		XX=24: 2400; 12: 1200; 48: 4800; 96: 9600
Interface data rate setting	55 AA	03	28 XY		X=0: no check; X=2 odd check; X=3: even check; Y=0: 9600; Y=1: 4800; Y=2: 2400; Y=3: 1200; Y=4: 600; Y=6: 19200
Channel No. reading	55 AA	03	24 00		return: 24 XX XX=01~10(16 channels)
RF data rate reading	55 AA	03	23 00		return: 23 XX XX refers to the setting of RF data rate
Serial number reading	55 AA	03	61 00		return: 61 S1 S2 S3 S4 S5 S6 S7 S8; S1~S8 indicates serial number
Version No. reading	55 AA	04	27 00 00		Return:27 1A XX XX: version No. 1A indicates FC-201/SA
frequency setting	55 AA	0B	58 XX T1 T2 T3 T4 R1 R2 R3 R4		XX=01~16, indicates channel 1 ~ 16 ; T1 ~ T4 indicates transmission frequency;R1~R4 indicates receiving frequency. e.g. if transmission frequency=483.0125MHz, T1~T4=48301250
frequency reading	55 AA	04	59 XX 00		return: 59XXT1T2T3T4R1R2R3R4 refers to frequency setting
Sleep mode setting	55 AA	04	58 00 XX		XX=b7b6b5b4b3b2b1b0 b7=1 sleep mode open b7=0 sleep mode close
Sleep mode reading	55 AA	04	59 00 00		return: 59 00 XX XX refers to sleep mode setting
Response to all the correct setting	55 AA	02	20		This command will response to a correct setting such as channel No., air data rate ,interface data rate, frequency and sleep mode setting.

## IX. Default setting and Accessories.

Factory default setting

Channel No.	1
Interface data rate	9600bps
RF data rate	9600bps
Check	no check

Accessories

User's manual	1
10-pin port	1
CD	1
	1